

REV	DESCRIPTION OF REVISION	E.C.N.	BY	APPROVED	DATE
A	ADDED TO SOLDER (RoHS EXEMPTED PER ANNEX 7)		E.T.W.		05-21-10

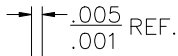

WOUND TIGHT AT THIS POINT

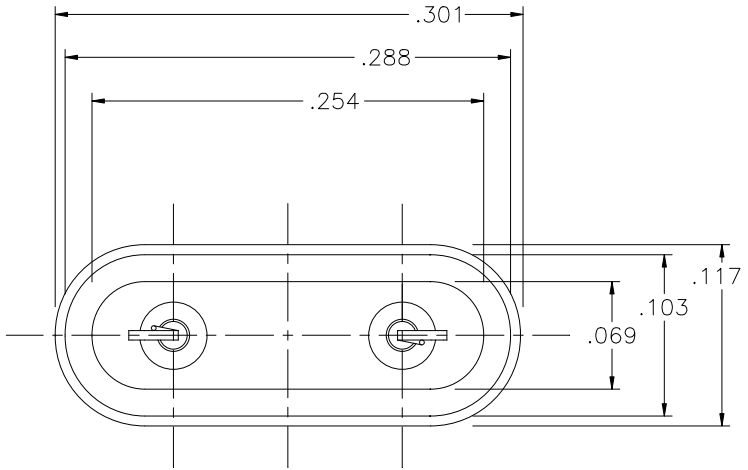
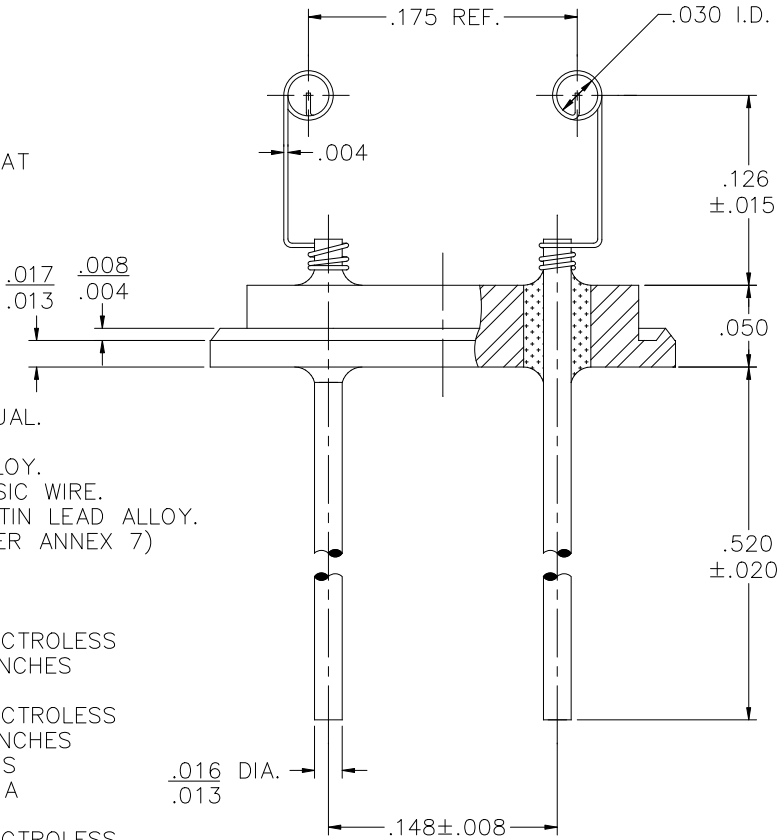

MATERIAL:

- EYELET - 1010 C.R.S. OR EQUAL.
- GLASS - 9013 OR EQUAL.
- LEADS - ASTM F-30, 52 ALLOY.
- SPRING - DOUBLE TINNED MUSIC WIRE.
- SOLDER - PER QQ-S-571-D TIN LEAD ALLOY.
(RoHS EXEMPTED PER ANNEX 7)

PLATING:

1. OPTION: RoHS COMPLIANT ELECTROLESS NICKEL PLATE OF 100 MICROINCHES MINIMUM FINAL PLATE.
2. OPTION: RoHS COMPLIANT ELECTROLESS NICKEL PLATE OF 100 MICROINCHES MINIMUM FOLLOWED BY A RoHS COMPLIANT SOLDER COAT OF A TIN ALLOY, ON LEADS ONLY.
3. OPTION: RoHS COMPLIANT ELECTROLESS NICKEL PLATE OF 100 MICROINCHES MINIMUM FOLLOWED BY A GOLD FLASH OF .99999 PURE 24 KARAT GOLD UP TO A MAX. OF 8 MICROINCHES.

DRAWN BY: E.T.W. 12-14-05		MATERIAL: SEE ABOVE		TOLERANCING PER ANSI Y14.5 .X ±.005 .XXX ±.005 .XX ±.005 ANG ±5° UNLESS OTHERWISE SPECIFIED		 Legacy Technologies Inc. 6700 W. 47th TERR. MISSION, KS. 66203 TEL: 913-432-2487 FAX: 913-432-0570
CHECKED BY:	APP. SPECS	SUPERSEDES	NEXT ASSY	SCALE: N.T.S.	FINISH: UNLESS OTHERWISE SPECIFIED	
APPROVED BY:	TITLE: HC-45/U TYPE RESISTANCE WELD W/SPRING MOUNT				PART NUMBER: RR-45-015-40145A-0 RoHS	A
				FILE: VA00030D	PAGE 1 OF 1	