

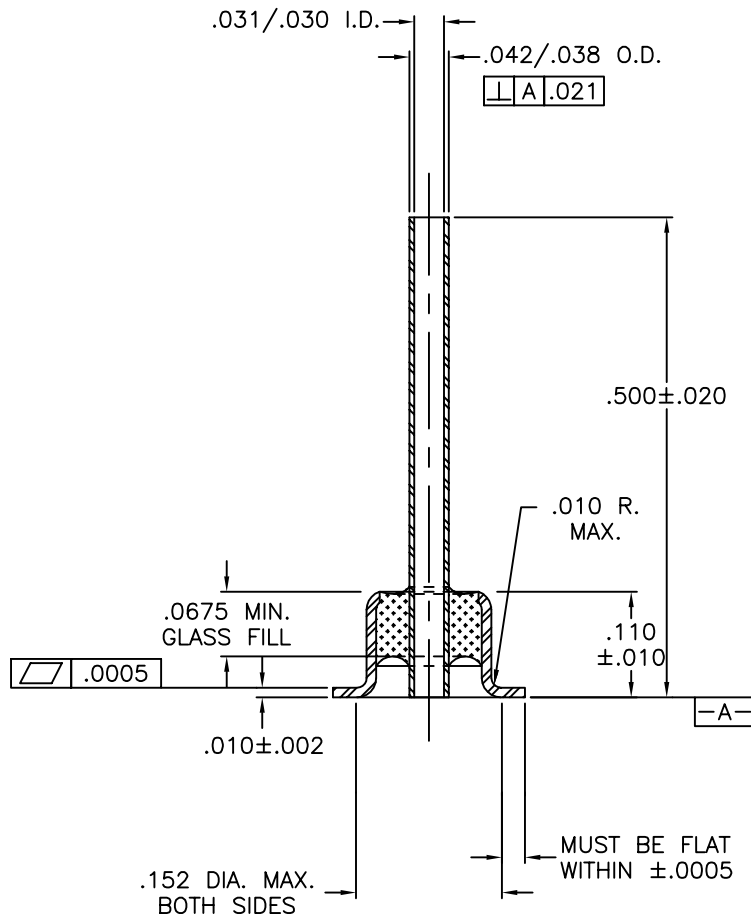

REV	DESCRIPTION OF REVISION	E.C.N.	BY	APPROVED	DATE
-----	-------------------------	--------	----	----------	------

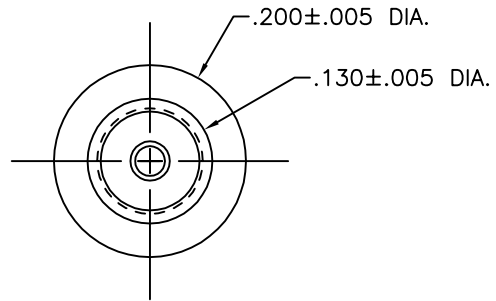

MATERIAL:
EYELET - ASTM F-15 ALLOY, KOVAR.
GLASS - 7052 OR EQUAL.
LEAD - ASTM F-15 ALLOY, KOVAR.

PLATING:
1. RoHS COMPLIANT ELECTROLESS NICKEL PLATE OF 100 MICROINCHES MINIMUM FOLLOWED BY 10 MICROINCHES MINIMUM OF ELECTROLYTIC GOLD PER MIL-G-45204B, TYPE 3, GRADE A, CLASS 00 REF.

DRAWN BY: E.T.W. 04-03-12	MATERIAL: SEE ABOVE			TOLERANCING PER ANSI Y14.5 .X ± .005 .XXX ± .005 .XX ± .005 ANG ± 5 UNLESS OTHERWISE SPECIFIED		 Legacy Technologies Inc. 6700 W. 47th TERR. MISSION, KS. 66203 TEL: 913-432-2487 FAX: 913-432-0570
	CHECKED BY: E.T.W. 04-03-12	APP. SPECS	SUPERSEDES	NEXT ASSY	SCALE: 5:1	
APPROVED BY:	TITLE: FILAMENT HEADER 730 FIXED PIN				PART NUMBER: FT-200-T040A RoHS G8	FILE: EA00114A
						PAGE 1 of 1